



HOLTEC GmbH & Co. KG
Anlagenbau zur Holzbearbeitung
Dommersbach 52
53940 Hellenthal
phone: +49 (0) 2482 / 82-0
fax: +49 (0) 2482 / 82-25
info@holtec.de
www.holtec.de

HOLTEC USA CORPORATION
P.O.Box 2190
FL-33509 Brandon
USA
phone: +1 - 813 / 754 16 65
fax: +1 - 813 / 752 80 42
info@holtecusa.com
http://www.holtecusa.com

BZH
Baljer & Zembrod, HOLTEC S.A.R.L.
Chemin de la Briquerie
Marolles - B.P. 223
F-51361 Vitry-le-Francois
FRANCE
phone: +33 - (0) 3.26.74.63.61
fax: +33 - (0) 3.26.74.07.16
contact@bzh-sarl.com

BZÖ
Baljer & Zembrod GmbH
Aderstrasse 44
A-4850 Timelkam
AUSTRIA
phone: +43 - 7672 / 95 475
fax: +43 - 7672 / 95 254
office@baljer-zembrod.at

HOLMAG
Holzbearbeitungsmaschinen AG
Mauer
CH-3454 Sumiswald
SWITZERLAND
phone: +41 - 34 / 43 12 723
fax: +41 - 34 / 43 11 262
info@holmag.ch
http://www.holmag.ch

RIVER DEE MACHINERY LTD.
The Old Telephone Exchange
Whitchurch Road
Bangor on Dee LI13 OAY
GREAT BRITAIN
phone: +44 - 19 78 / 780 920
fax: +44 - 19 78 / 780 900
sales@riverdee.net
http://www.riverdee.net

SAGSPECIALISTEN AB
Soldattorpsgatan 12
S-55474 JÖNKÖPPING
SWEDEN
phone: +46 - 36 / 396 690
fax: +46 - 36 / 138 888
info@sagspecialisten.se
http://www.sagspecialisten.se

HOLTEC TIMBER TECHNOLOGY
P.O.Box 159
West Park Village
NZ-1008 Auckland
NEW ZEALAND
phone: +64 - 9 41682 94
fax: +64 - 9 41682 96
sales@holtec.org
http://www.holtec.co.nz

A. FALKENBERG EFTF.AS
Billingstadsletta 30
NO-1377 Billingstad
NORWAY
phone: +47 - 66 77 89 00
fax: +47 - 66 77 89 01
info@falkenberg.no
http://www.falkenberg.no

PENOPE OY
Tupalankatu 9
FIN-15680 Lahti
FINLAND
phone: +358 - 3 87 87 0
fax: +358 - 3 87 87 500
info@penope.fi
http://www.penope.fi

SIA OBERTS
Marupites Gatve 9a
Rigas raj.
LV-2167 Marupes Pag
LATVIA
phone: +371 - 6781 0666
fax: +371 - 6781 0655
andris@oberts.lv
http://www.oberts.lv

PFZ
Przedstawicielstwo Firm
Zagranicznych
Kubiak-Wasilewski s.c.
ul. Opolska 33
PL-91-604 Lodz
POLAND
phone1: +48 - 42 6 508 637
phone2: +48 - 42 6 339 932
Mobil: +48 - 601 299 933
jacek@pfz.pol.pl
http://www.holtec.republika.pl

HOLTEC Representative RUSSIA
Ekaterina Chernobrovaya
Sankt Petersburg
RUSSIA
phone: +7 - 495 988 28 84
fax: +49 - 2482 / 8225
echernobrovaya@holtec-online.de
http://www.holtec-stanki.ru

**NEW CENTURY SAWMILL
SOLUTIONS PTY LTD.**
P.O. Box 10840
ZA-0046 Centurion
SOUTH AFRICA
phone: +27 - 12 6633 885
fax: +27 - 12 6638 975
info@newsaw.co.za

MAMA TECHNOLOGY LTD.
Import & Marketing Machines
1 Shfaraamstr.
Nazareth 16000
ISRAEL
phone: +972 - 524 265 800
fax: +972 - 465 565 62
mama.technology@hotmail.com

J. MANUEL CASANOVA
C./Font De La Fusta, 8
08415 Bigues I Riells (Barcelona)
SPAIN
phone: +34 - 93 8 657 552
fax: +34 - 93 8 656 129
jmcg59@telefonica.net

Wood First, Lda
Rua do Sindico N° 53
3810-805 OLIVEIRINHA / AVEIRO
PORTUGAL
phone: +351 - 234 - 942530
fax: +351 - 234 - 942530
virgilio.pereira@woodfirst.pt

variocut
HOLTEC | Type SHK
with stationary
saw unit

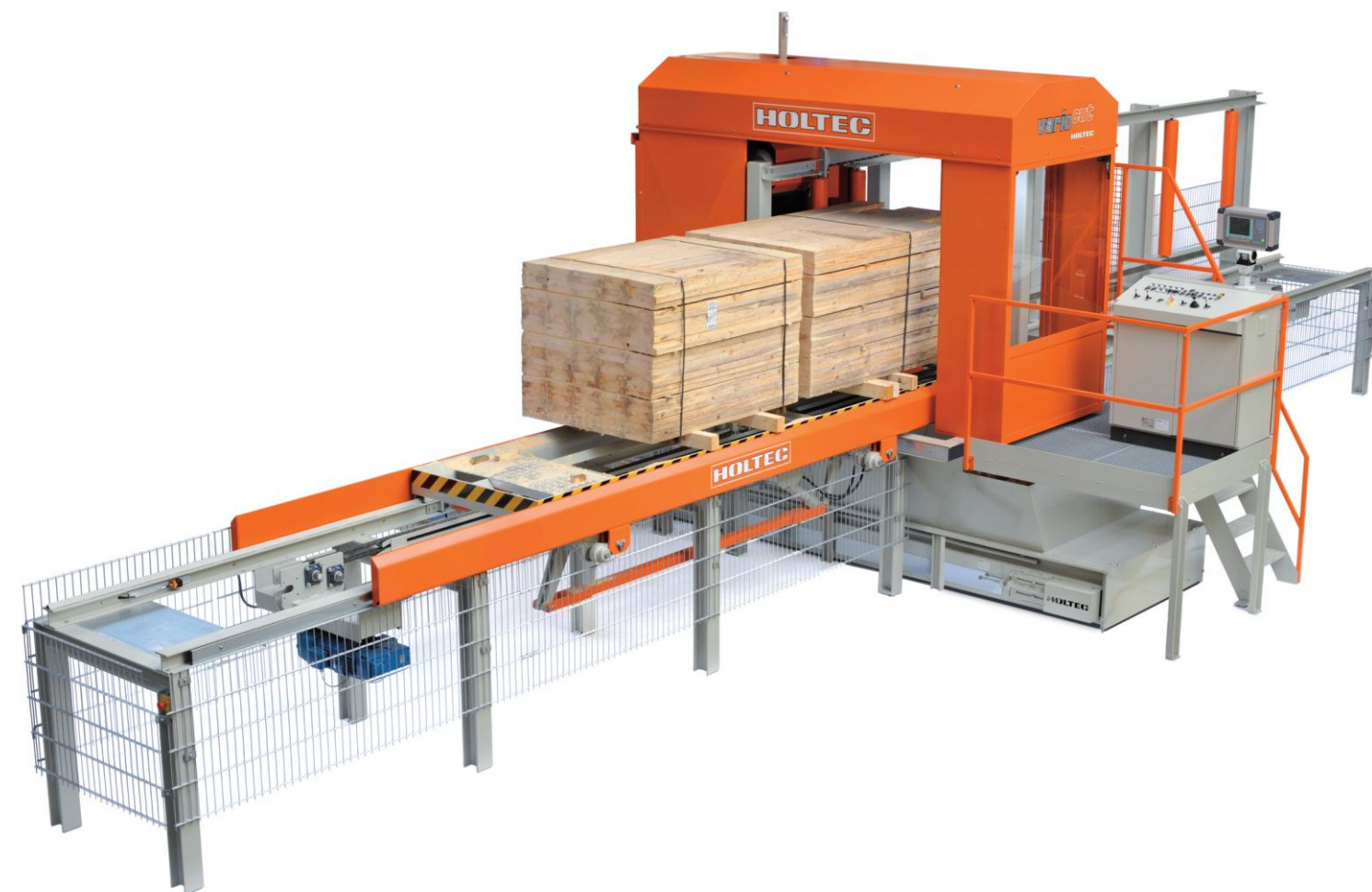

Stand 7/2011



variocut
HOLTEC | Type SHK
with stationary
saw unit

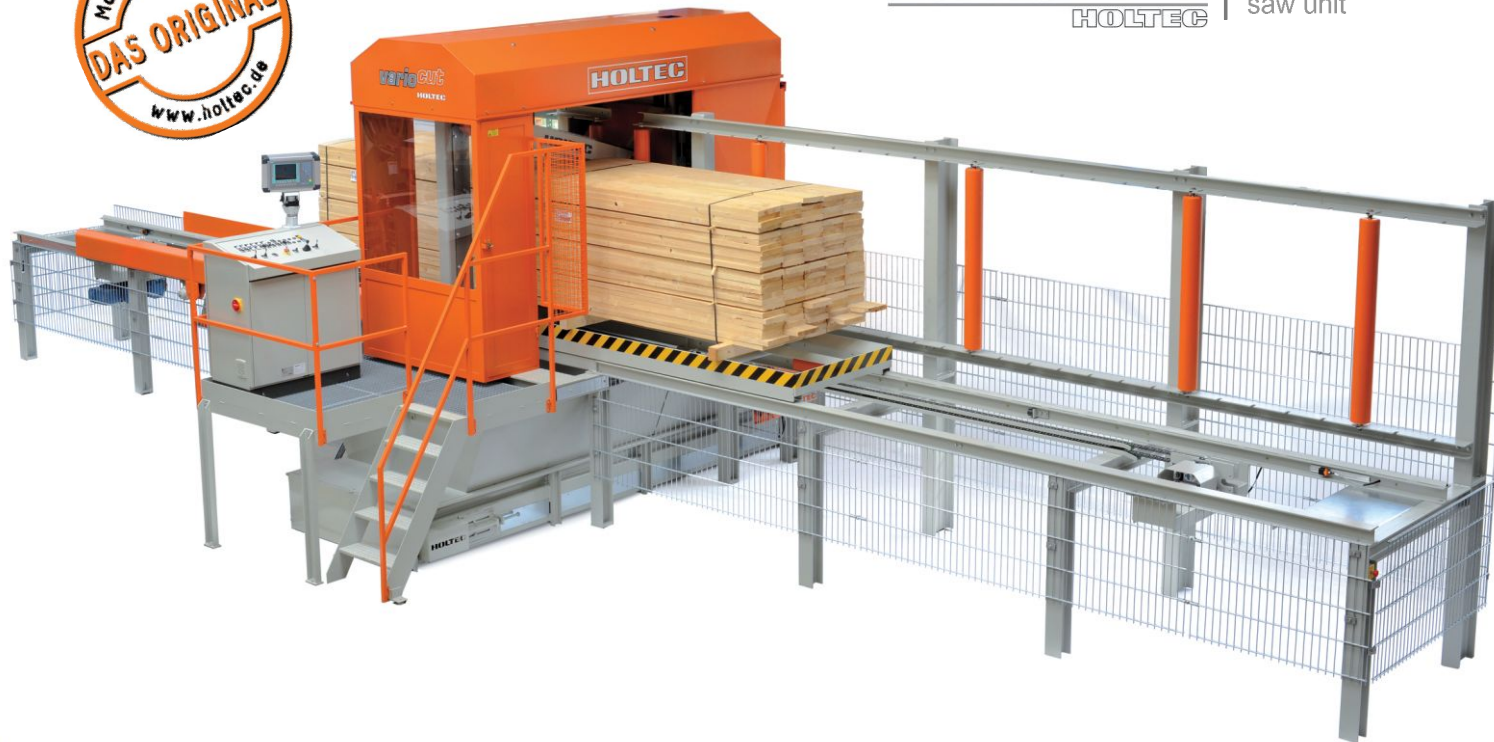

Package crosscut saw Vario-Cut with moveable carriage and stationary saw unit. The packages are positioned by means of an electrically controlled carriage. During the cutting process the guide bar can be guided through the package in an angle of 0-15°. The cutting of partial packages is possible on any package height. By means of the parallelogram set-off device the cutting kerf can be opened - condition for optimally carrying out multiple cuts within one package.

Technical specifications - standard system

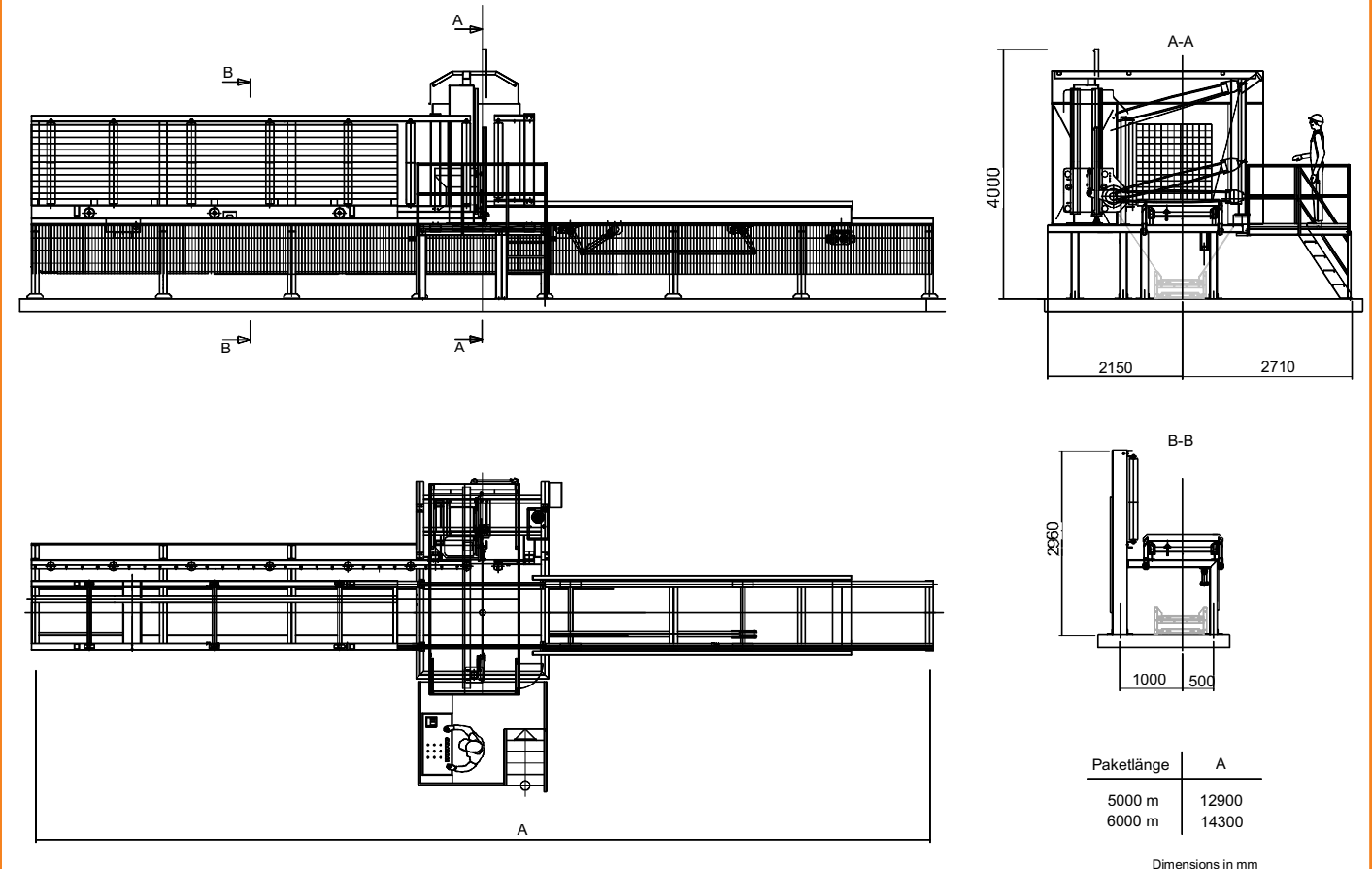

Subject to technical amendments. All dimensions without commitment.



Variable cutting angle of 0 to 15° for optimal distribution of the cutting forces



Available with several control options



Sharpening unit included in the scope of supply



Available with integrated waste conveyor

The Vario-Cut series is especially designed for the needs of high-capacity operations. A rugged saw unit, a vertically running guidance of the guide bar and the possibility of the variable guide bar control during the cutting process characterize this machine type. Equipped with 15-kW drive for short cycle times during cutting process and high capacity.

- Maximum cutting accuracy by cutting assembly guided on both sides
- Electric positioning
- Hydraulic saw feed, continuously adjustable
- System lengths up to 10 m
- Guide bar length 160 cm
- Maximum package cross section 1,2 m x 1,2 m
- Saw drive 15 kW

Additional equipment

- Automatic cutting sequence by control of the cutting process
- Integrated waste evacuation
- Cutting depth adjustment

HOLTEC cutting assembly = highest quality

- Guide bar completely stellite armoured and 4-fold turnable
- Equipped with original **STIHL**-chain with patented Oilomatic principle
- **STIHL**-lubrication oil for a long lifetime of chain, guide bar
- Everything from one source - Machine, cutting assembly and service
- HOLTEC sharpening service - for best cutting results and long lifetimes

- ① Fast chain replacement without additional tools
- ② Patented **STIHL**-chain lubrication system for long lifetime
- ③ Available with hard-chromed or carbide tipped **STIHL**-scratcher chain

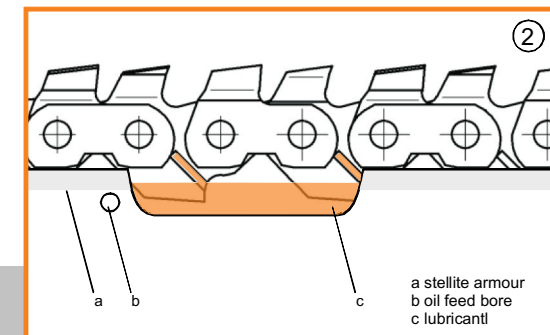
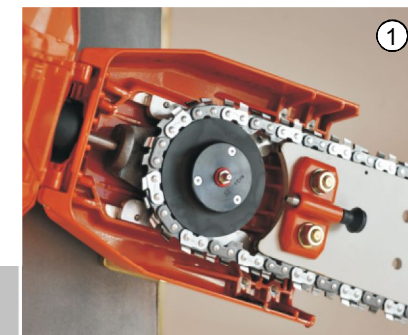

PACKAGE CROSSCUT SAWS